



FAURE
ÉQUIPEMENTS
ΕΠΙΒΕΒΩΝΙΣ
ΛΥΟΚΕ

Filter Presses

LEADING MECHANICAL DEWATERING SYSTEM: THE FILTER PRESS.

Advantages of filter presses:

- ◆ High performance in terms of dryness (30 to 80%)
- ◆ Simplicity, robustness, reliability
- ◆ Low operating costs
- ◆ Standardisation of automatic filter presses.
Automatic operation up to 24 h/24



TITAN automatic filter press



Filter cake discharge



Cake storage

DESCRIPTION

Filter presses are used to filter suspensions to separate liquid and solid phases.

They comprise a set of plates covered with filter cloths, creating watertight chambers into which the product to be filtered is injected under pressure.

Under this pressure, the liquids pass through the cloths, which retain the solid particles. The filtrates are evacuated throughout the pressing cycle. The cakes formed between the plates are released in the discharge phase. Membrane plate (mixed pack) technology combines the conventional filtration phase with a compression phase at the end of the pressing cycle. Membrane filter press technology improves filter press productivity by 20 to 50% and increases the dryness of the cake.

Cake discharge is automated, using combined shaking and automatic weight-monitoring systems developed by us.

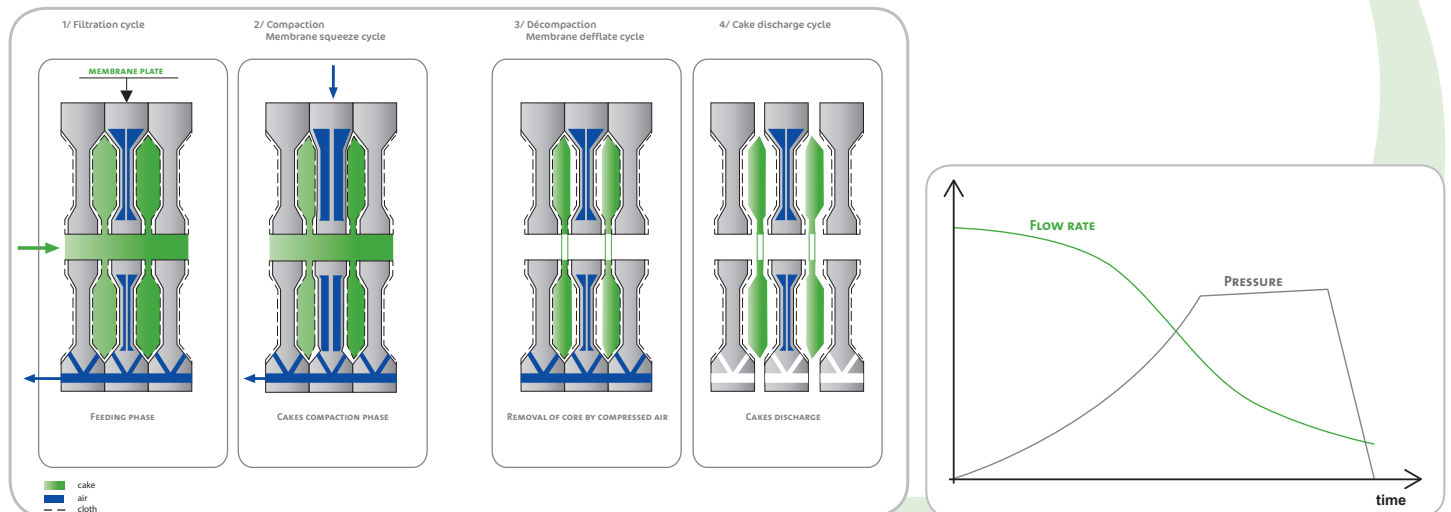

DESCRIPTION	PLATES SIZE (mm)	MAX NBR OF PLATES	FILTERING SURFACE (m ²)	MAX VOLUME (l)
207	250*250	10	0.85	98
212	500*500	50	21	290
211	630*630	70	47	658

DESCRIPTION	PLATES SIZE (mm)	MAX NBR OF PLATES	FILTERING SURFACE (m ²)	MAX VOLUME (l)	HYDRAULIC UNIT POWER RATING (Kw)
TITAN 217	800*800	110	107	1450	4
TITAN 218	1000*1000	125	205	2800	5.5
TITAN 219	1200*1200	140	325	4200	4
TITAN 219B	1300*1300	145	385	5100	4
TITAN 220	1500*1500	160	590	8000	7.5
TITAN 220B	1500*2000	170	840	10660	11
TITAN 226	2000*2000	180	1140	17800	15

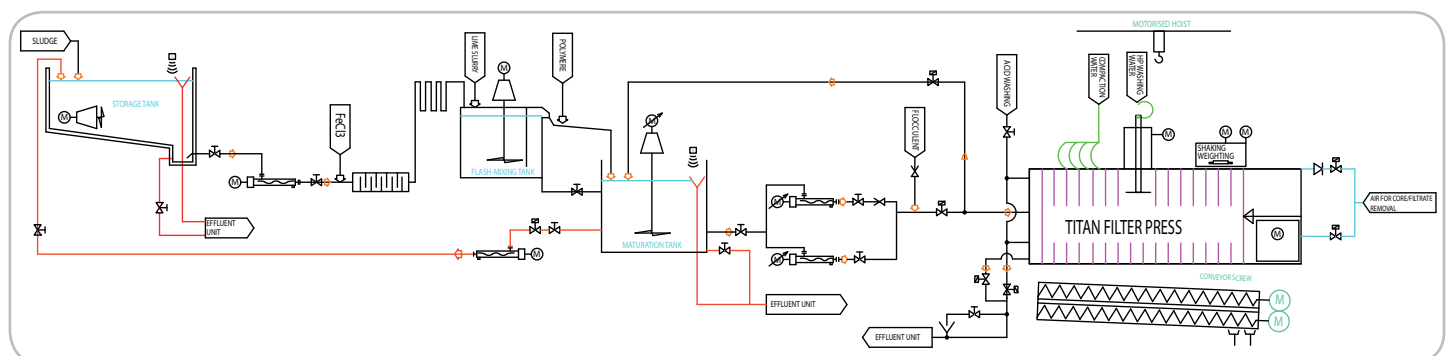

DESIGN

Robust construction ensures a perfect distribution of forces.

Lateral beams support the plate pack as well as the standard and automatic cake discharge equipment.

The chamber or membrane (mixed pack) plates can range from 250*250 to 2000*2000 in size.

The hydraulic unit is used to open and close the filter press and to keep it under pressure.



Automatic cake discharge boom

Cake discharge

- **100% automatic:** the device for shaking the plates is connected to a weighing system which ensures that the cakes are discharged **without operator intervention.**
- anti-corrosion mechanised cake discharge: this accurate and reliable device enables the chambers to open without operator intervention. The stainless steel material ensures that they remain in perfect condition over time.



High-pressure cloth washing

High-pressure cloth washing

An automatic washing robot is connected to the cake discharge system to optimise the cleaning process.

Acid washing

An acidified water solution is injected into the filter press, using a controlled dosage unit.



Cake collection

Cake collection

- Directly into a skip positioned under the filter press, using a guide funnel. Automatic shutters close the trap
- By conveyor (conveyor belt or continuous screw) to skips or a storage area.



Electrical control cabinets

Electrical control cabinets

Designed by our electrical equipment department, these control all or part of the dewatering plant (remote control and power supply). They also incorporate the latest technology and meet the strictest specifications (standards, materials, etc.).



Protection of personnel

Protection of personnel

This is provided by light curtains and grating panels which comply with the current regulations (CE as a standard).



Filter press peripherals

Filter press peripherals

The following units can be added to our equipment to produce a turnkey plant: transfer pumps, dosage pumps, agitators, flocculation tank, settlement tank, reactor, etc.

Advantages of filter presses:

- ◆ High performance in terms of dryness (30 to 80%)
- ◆ Simplicity, robustness, reliability
- ◆ Low operating costs
- ◆ Very low consumption of energy and reagents
- ◆ Greatly reduced labour requirements
- ◆ Adaptable to changes in production, concentration, conditioning requirements.
- ◆ Standardisation of automatic filter presses. Cake discharge without operator intervention. Continuous operation 24 h/24
- ◆ Adaptable to different effluent treatment methods: physical-chemical, biological, electroflocculation, etc.
- ◆ Excellent capture rate for suspended matter
- ◆ Low maintenance costs
- ◆ Fast and profitable return on investment
- ◆ High level of flexibility in operation

Areas of application

DEWATERING OF SLUDGES FROM:

- Urban effluent and effluent from drinking water plants
- Industrial effluent: examples:
 - Agri-food industry
 - Mines and quarries
 - Pollution treatment
 - Hydrometallurgy
 - Surface treatment
 - Exhaust gas scrubbing
 - etc.

INDUSTRIAL FILTRATION PROCESSES

- Agri-food industry (sugar, oils, wine, algae, etc.)
- conventional and composite ceramics
- chemical industry
- pharmaceutical industry



www.faurequip.com



FAURE
ÉQUIPEMENTS
ΕΠΙΒΕΒΕΜΕΝΤΣ
ΕΥΡΩΠΕ

Automatic Filter Presses

OUR EXPERIENCE

Advantages:

- ◆ Runs 24h/24 without operator intervention
- ◆ Reduced capital and operating costs
- ◆ Less space required
- ◆ Integration into continuous automatic processes
- ◆ Simple, robust and reliable

We are standardising our range of automatic filter presses in response to our customers' productivity requirements.

With an automatic filter press, the process cycles follow each other without the intervention of an operator, particularly in the cake discharge phases.

An automatic filter press dewatering plant not only has an automatic filter press but also an optimised sludge conditioning line and feed pumps selected and sized by us.

Automatic filter presses have:

- A plate-shaking system which detaches firmly adhered cake.
- A plate-weighing system for automatic control of the release of the cake.

This simple and inexpensive solution leaves the cloths untouched and ensures that they remain intact.



Automatic cake discharge boom



Cake discharge



Automatic cake storage

TYPES OF AUTOMATIC FILTER PRESS



We supply two types of automatic filter press:

- **Short FPs:**

The plates are chained together and a cam shaft shakes the whole pack. These filters are intended primarily for short filtration cycles (suspended matter of mineral origin).

- **Standard FPs:**

The plates are shaken and the cake released from them individually. The shaking system is mounted on a boom connected to the discharge system. These filters are suitable for long filtration cycles (suspended matter of organic origin).

- **Principle of automatic control by weight:**

Release of the cakes is controlled by weight, either of the whole plate pack, or of each plate, depending on the type of filter press.

If the automatic system detects that the tare weight (weight of the empty plate) has been exceeded, this means that there is a cake which has not been discharged. The shaking system is then activated.

Membrane plate technology is generally used for automatic filter presses. In fact, this technique produces optimal results in terms of dryness, cake quality and productivity (dryness, homogeneity, discharge).

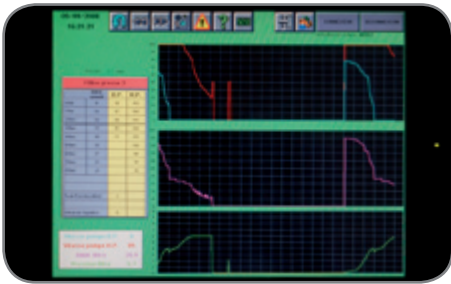

TECHNICAL PROPERTIES

The benefits of automatic filter presses are evident from the numerous references available. Automatic filter presses can be used for all types of sludge (organic and mineral) in quantities from 20 kg to 100 t of suspended matter per day.



www.faureequip.com



FAURE
ÉQUIPEMENTS
EQUIPMENTS
EQUIPMENTS

Mobile Filter Presses

Advantages :

- High degree of dryness obtained (30 to 80%, depending on the sludge)
- Robust, adaptable and reliable equipment
- High productivity
- Completely independent
- Very easy to use
- Fast opening and closing of the unit
- Particular cost benefits for container solutions

We have developed a range of mobile filter presses in response to the requirement for dewatering urban or industrial sludges in situ. This equipment is used in cycles by different service providers.

To provide an even better solution, our mobile units are designed to integrate all types of filter press - chamber or mixed pack - of different sizes with the sludge conditioning and cake conveyor equipment.

The output of these mobile units, varies depending on their size: from 250 to 6,000 litres of cake per cycle, which is equivalent to 100 to 4,500 kg of dry matter per 1 to 2 hour pressing cycle, depending on the type of organic or mineral sludge.

Dryness varies between 30 and 80%, depending on the sludge treated, in accordance with the current regulations.



Cake removal



cake storage



cake produced



Depending on the quantity of dry material to be treated, we design mobile units on conventional semi-trailers or transporters, as well as filter presses installed in maritime containers or directly on a steel chassis.

Also incorporated are:

- the filter press transfer and feed pumps
- injection and preparation of the conditioning agent (FeCl₃, polymer, chalk, etc.)
- cake-removal systems



Cake removal by screw conveyor



Services: Faure Equipements designs, manufactures, installs and commissions these mobile units



Installation in a maritime container



Long-term installation

www.faureequip.com



FAURE
ÉQUIPEMENTS
EQUIPMENTS
FAURE

Research and Development Department

A LABORATORY ENABLING:

• IDENTIFICATION OF THE PROPERTIES OF SLUDGES AND PRODUCTS

Faure Equipements has equipment to identify the properties of the sludges and products to be dewatered (Jartest, measurement of CST, suspended matter, dryness, etc.). We also have a compressibility chamber complying with standard NFT 97-001. This equipment, with computerised data acquisition, makes it possible to determine the parameters that characterise the dewatering phases (maximum dryness, compressibility, specific strength of the cakes).

• CONDUCTING PILOT TESTS IN THE LABORATORY

The laboratory filter press we have designed and developed enables the dryness, density and filtration times to be determined, using a small volume of sludge (a few litres). It also allows dewatering tests to be conducted on membrane plates or specific phases (for example cake drying and washing).



Maximum dryness chamber

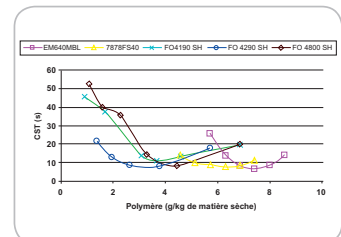
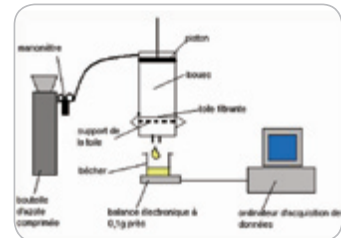

Acquisition of results

INDUSTRIAL TESTS

• INDUSTRIAL PILOT



Where the volumes justify it or where industrial scale tests are essential, we have several test platforms which can be easily transported within France or abroad. This equipment is fitted with the latest technology (membrane plates, automatic cake discharge system) and can be used to conduct all operations which can be carried out on a filter press. Combined with complete conditioning systems on a skid, these test platforms constitute real industrial test beds.

The following parameters are checked:

- For conventional dewatering
 - Pressures
 - Flow rates
 - Results (dryness, density, productivity)
- For developing the processes
 - Parameter for extraction by washing/blowing
 - Water and air pressure and flow rate required
 - Results (residual humidity, rate associated with washing/blowing, etc.).

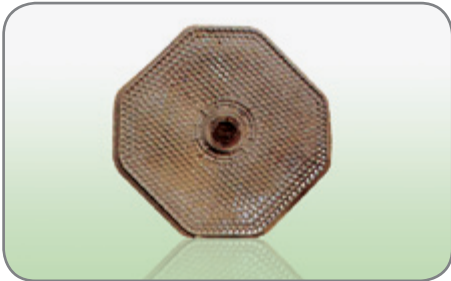

• LABORATORY SERVICES

With the different laboratory equipment or mobile test platforms, we can provide a full range of expertise to solve your filtration problems and to optimise the existing lines,

- check the dewatering options for your products and guarantee the results,
- research new conditioning systems.

• FULL-SCALE TEST ON MOBILE FILTER PRESS

Standard mobile filter press unit for 2,800 litres of cake per cycle



www.faureequip.com